

User Manual
SKU: ABX00100

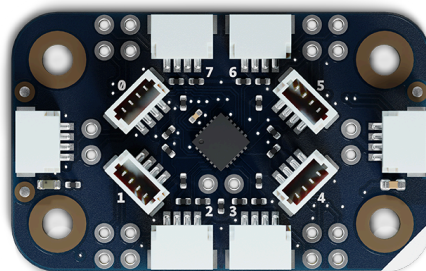

Description

The Modulino Hub features the TCA9548ARGER I2C multiplexer, providing eight independent I2C channels through a single main bus connection. This powerful module enables complex I2C networks by allowing multiple devices with identical addresses to coexist on separate channels, making it ideal for expanding large-scale sensor networks and complex modular projects.

Target Areas

Maker, beginner, education, advanced prototyping



Contents

1 Application Examples	3
2 Features	4
2.1 Contents	4
3 Related Products	4
4 Rating	4
4.1 Recommended Operating Conditions	4
5 Power Tree	5
6 Block Diagram	5
7 Functional Overview	6
7.1 Technical Specifications (Module-Specific)	6
7.2 Pinout	7
7.3 Power Specifications	9
7.4 Mechanical Information	9
7.5 I2C Address Reference	11
8 Device Operation	12
8.1 Using Multiple Hubs	12



1 Application Examples

- **Address Conflict Resolution** Connect multiple sensors or modules with the same I2C address by placing them on different Hub channels.
- **Large Sensor Networks** Build complex monitoring systems with dozens of sensors organized across multiple independent I2C buses.
- **Modular Project Expansion** Scale projects from simple single-sensor setups to comprehensive multi-sensor installations without having to redesign them.

2 Features

- **TCA9548ARGER** I2C multiplexer with **eight independent channels**.
- Each channel includes **4.7 kΩ pull-up resistors** for reliable I2C operation.
- **Voltage translation** capability for mixed-voltage I2C systems.
- **Ten Qwiic connectors**: 2 main bus, 8 channel outputs (4 horizontal, 4 vertical).
- **Three address selection jumpers** allowing up to **8 Hubs** on the same bus (64 total channels).
- **Default I2C address 0x70** with seven additional addresses available.
- **Optional RESET pin** for manual or programmatic channel reset.
- Operates at **3.3 V** via the Qwiic interface.

2.1 Contents

SKU	Name	Purpose	Quantity
ABX00100	Modulino Hub	I2C multiplexer with 8 independent channels	1
	I2C Qwiic cable	Compatible with the Qwiic standard	1

3 Related Products

- **SKU: ASX00027** – Arduino® Sensor Kit
- **SKU: K000007** – Arduino® Starter Kit
- **SKU: AKX00026** – Arduino® Oplà IoT Kit

4 Rating

4.1 Recommended Operating Conditions

- **Supply voltage**: 3.3 V
- **Powered at 3.3 V** through the Qwiic interface (in accordance with the Qwiic standard)
- **Operating temperature**: -40 °C to +85 °C

Typical current consumption:

- TCA9548ARGER idle: ~3 µA
- Active operation: ~50 µA (varies with number of active channels)

5 Power Tree

The power tree for the Modulino node can be consulted below:

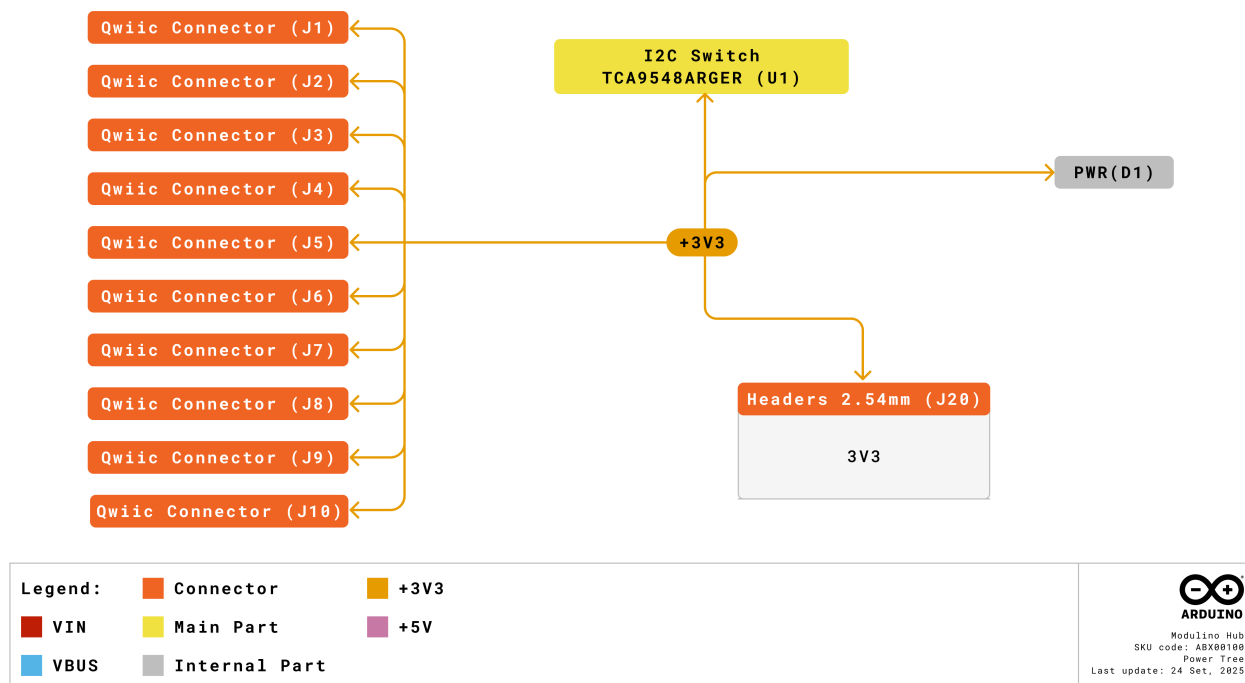

Modulino Hub Power Tree

6 Block Diagram

This module features a TCA9548ARGER I2C multiplexer that creates eight independent I2C channels from a single main bus. Each channel can be individually enabled or disabled via I2C commands to the multiplexer.

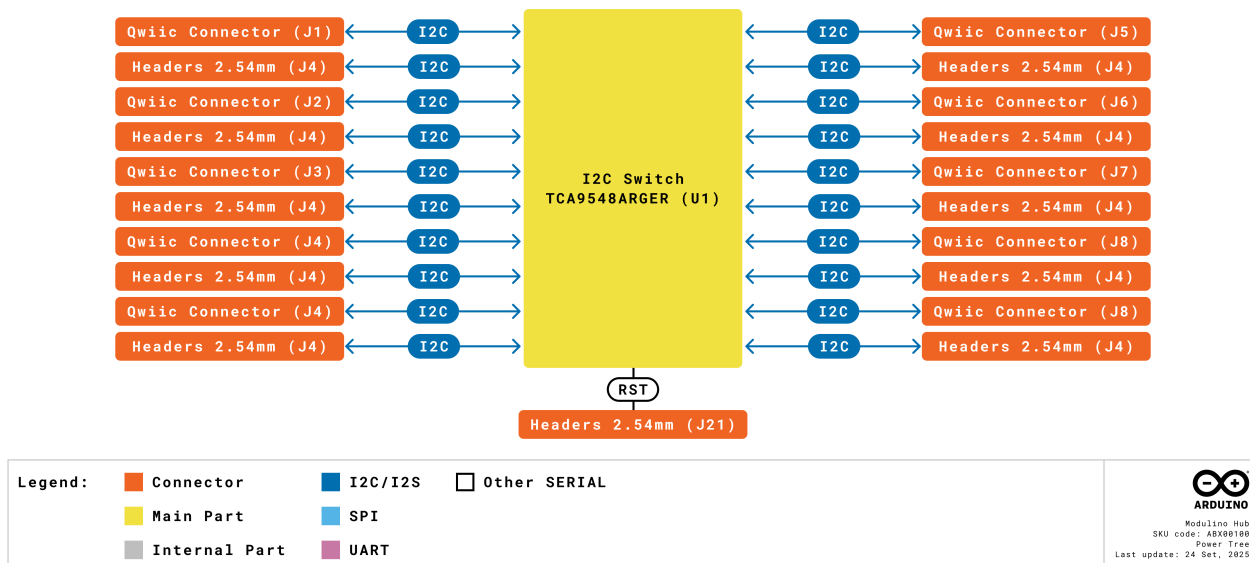

Modulino Hub block diagram

7 Functional Overview

The Modulino Hub acts as an intelligent I2C switch, routing the main I2C bus to any combination of its eight output channels. The TCA9548ARGER allows multiple channels to be active simultaneously or individually, controlled by writing to its configuration register. Each channel has independent 4.7 kΩ pull-up resistors to ensure signal integrity. This design solves the common problem of I2C address conflicts by isolating devices with identical addresses on separate channels.

7.1 Technical Specifications (Module-Specific)

Specification	Details
I2C Multiplexer	TCA9548ARGER
Number of Channels	8 independent I2C channels
Pull-up Resistors	4.7 kΩ on each channel (SDA and SCL)
Communication	I2C (Qwiic)
Address Range	0x70–0x77 (selectable via jumpers)

7.2 Pinout

Main Qwiic Connectors (2×, 1×4 each)

Pin	Function
GND	Ground
3.3 V	Power Supply (3.3 V)
SDA	I2C Data (main bus)
SCL	I2C Clock (main bus)

These two connectors allow daisy-chaining the Hub with other Modulino nodes on the main I2C bus.

Channel Connectors

Horizontal Connectors (4×, on long sides)

- Channel 2 (SC2/SD2)
- Channel 3 (SC3/SD3)
- Channel 6 (SC6/SD6)
- Channel 7 (SC7/SD7)

Vertical Connectors (4×)

- Channel 0 (SC0/SD0)
- Channel 1 (SC1/SD1)
- Channel 4 (SC4/SD4)
- Channel 5 (SC5/SD5)

Each channel connector provides: GND, 3.3 V, SDA (channel), SCL (channel)

Optional Headers (not mounted, holes provided)

1×4 Main Bus Header

Pin	Function
GND	Ground
3V3	3.3 V Power
SDA	I2C Data
SCL	I2C Clock

1×2 Headers for Each Channel (8 total) Each provides access to that channel's SDA and SCL lines for custom connections.

1×1 RESET Header Optional connection for manual or programmatic reset of the TCA9548ARGER.

Note:

- Address selection via three solder jumpers on the bottom of the board (A0, A1, A2).
- Default address is 0x70 (all jumpers open).
- Up to 8 Hubs can share the same main bus with different addresses.

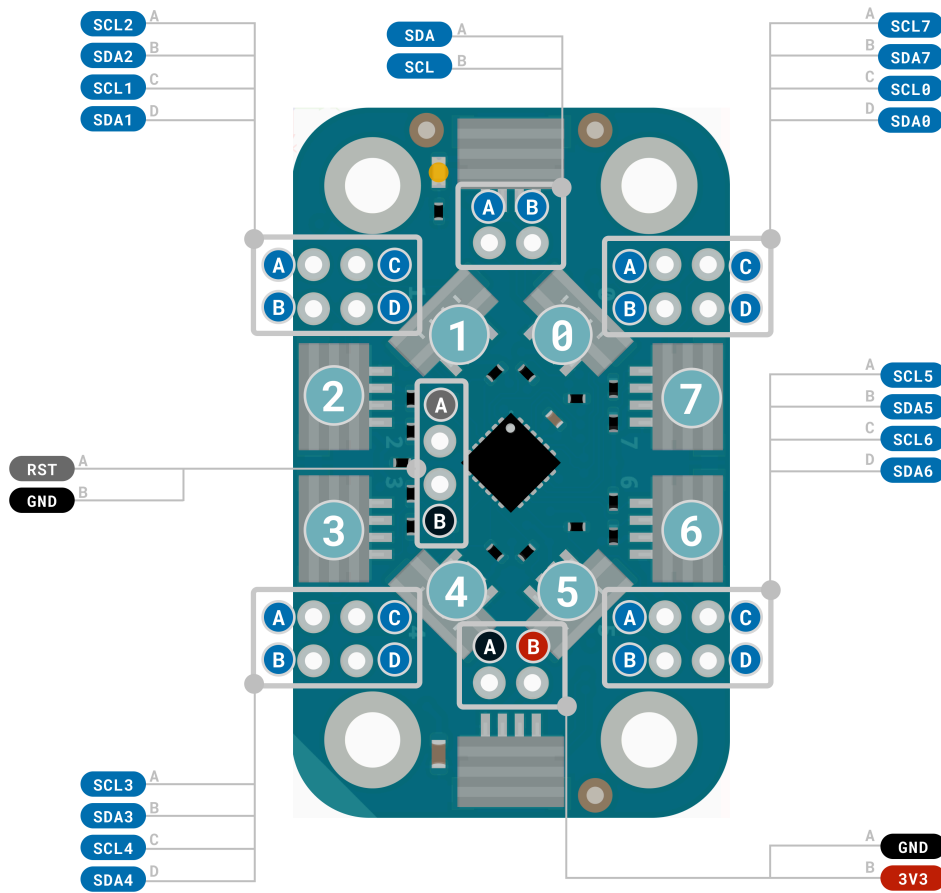

Legend:	Digital	I2C	Other SERIAL
Power	Analog	SPI	Analog
Ground	Main Part	UART/USART	PWM/Timer

Modulino Hub
SKU code: ABX00100
Pinout
Last update: 23 Jan, 2026

Pinout Overview

7.3 Power Specifications

- **Nominal operating voltage:** 3.3 V via Qwiic
- **TCA9548ARGER voltage range:** 1.65 V–3.6 V

7.4 Mechanical Information

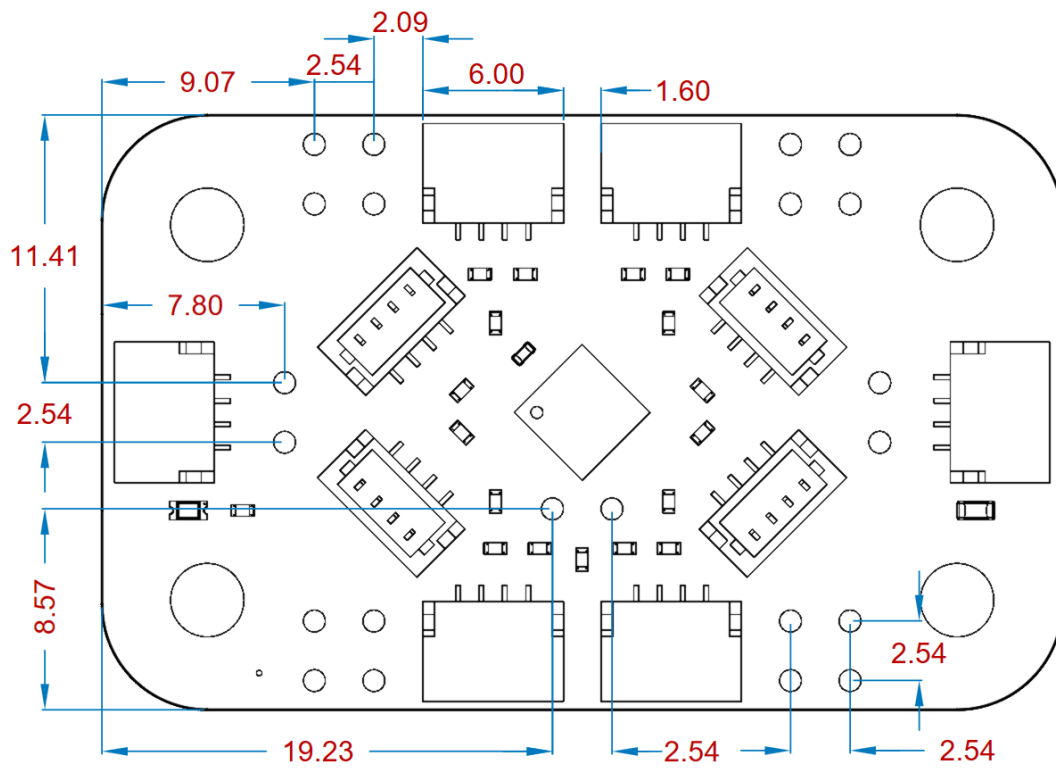

Modulino Hub Mechanical Information

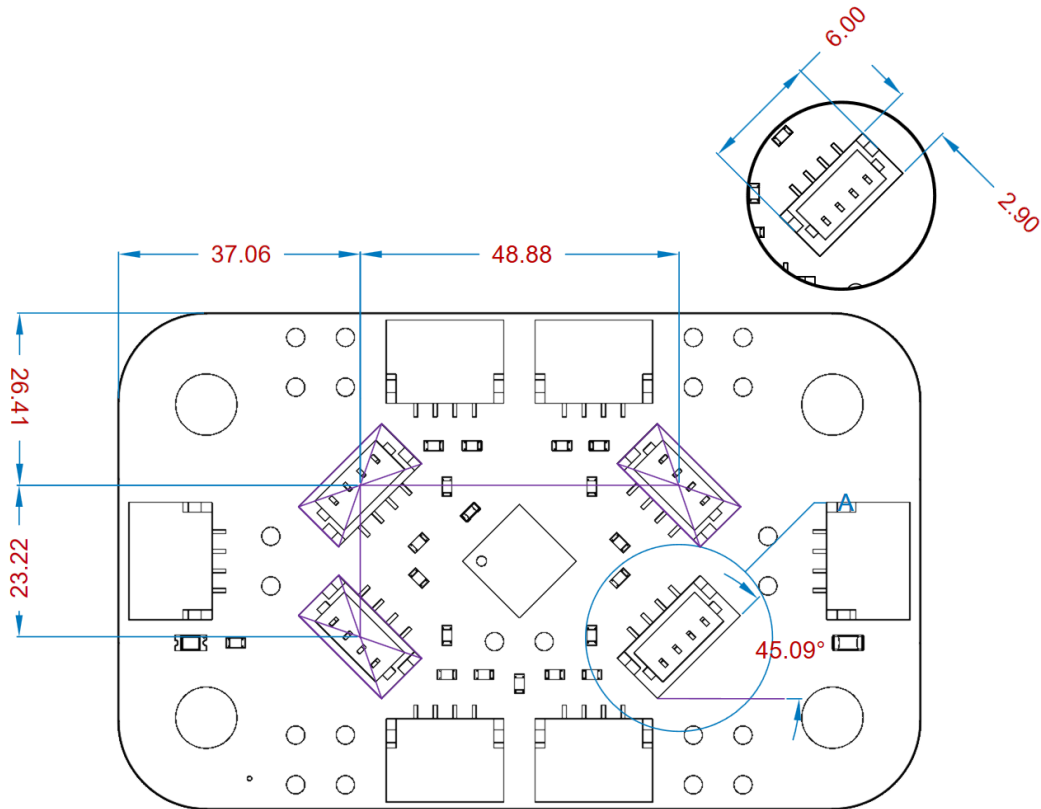

Modulino Hub Mechanical Information - Alternative View

- Board dimensions: 41 mm × 25.36 mm
- Thickness: 1.6 mm (±0.2 mm)
- Four mounting holes (Ø 3.2 mm)
 - Hole spacing: 16 mm vertically, 32 mm horizontally

8 Device Operation

The Hub operates as an I2C target device on the main bus. After power-up, all channels are disabled by default. To enable channels, write to the TCA9548ARGER control register at the Hub's I2C address. Each bit in the control register corresponds to one channel (bit 0 = channel 0, bit 1 = channel 1, etc.). Multiple channels can be enabled simultaneously by setting multiple bits. Once enabled, devices on those channels become accessible from the main bus.

8.1 Using Multiple Hubs

Up to 8 Hubs can coexist on the same main I2C bus by configuring different addresses via the solder jumpers. This creates up to 64 independent I2C channels (8 Hubs × 8 channels each), enabling extremely complex sensor networks and modular systems.

Company Information

Company name	Arduino SRL
Company Address	Via Andrea Appiani, 25 - 20900 MONZA (Italy)

Reference Documentation

Ref	Link
Arduino IDE (Desktop)	https://www.arduino.cc/en/Main/Software
Arduino Courses	https://www.arduino.cc/education/courses
Arduino Documentation	https://docs.arduino.cc/
Arduino IDE (Cloud)	https://create.arduino.cc/editor
Cloud IDE Getting Started	https://docs.arduino.cc/cloud/web-editor/tutorials/getting-started/getting-started-web-editor
Project Hub	https://projecthub.arduino.cc/
Library Reference	https://github.com/arduino-libraries/
Online Store	https://store.arduino.cc/



Revision History

Date	Revision	Changes
23/03/2026	1	First release