

Description

The Arduino Due is a groundbreaking microcontroller board featuring the Atmel SAM3X8E ARM Cortex-M3 CPU, making it the first Arduino board built around a 32-bit ARM core microcontroller. With its 54x digital input/output pins, 12x analog inputs, 4x UARTs, USB OTG capability, and 84 MHz clock, the Due offers enhanced performance and versatility for a wide range of projects. Compatible with all Arduino shields designed for operation at 3.3 V and compliant with the 1.0 Arduino pinout standard, the Due is a powerful tool for both beginners and experienced makers alike.

Target Areas

Embedded Systems Development, Robotics, 3D Printing, CNC Machines, Prototyping

Contents

1 Application Examples	4
2 Features	5
2.1 General Specifications Overview	5
2.2 Microcontroller	5
2.3 Inputs	6
2.4 Outputs	6
3 Accessories	6
4 Related Products	6
5 Rating	6
5.1 Recommended Operating Conditions	6
5.2 Power Specification	7
5.3 Current Consumption	7
6 Functional Overview	8
6.1 Pinout	8
6.2 Full Pinout Table	9
6.2.1 Board's 24-Pin Header	9
6.2.2 Board's 26-Pin Header	10
6.2.3 SPI	11
6.2.4 Digital Pins D22 - D53 LHS	11
6.2.5 Digital Pins D22 - D53 RHS	12
6.2.6 JTAG Pins	12
6.3 Block Diagram	13
6.4 Power Supply	14
6.5 Product Topology	15
6.5.1 JTAG Connector	16
6.5.2 Native USB Port	16
6.5.3 Programming USB Port	17
6.5.4 Board's 24-Pin Header Connector	17
6.5.5 Board's 26-Pin Header Connector	18
6.5.6 SPI	19
6.5.7 D22 to D53 on Left and Right Side	19
7 Device Operation	21
7.1 Getting Started - IDE	21



7.2 Getting Started - Arduino Web Editor	21
7.3 Getting Started - Arduino Cloud	21
7.4 Online Resources	21
7.5 Board Recovery	21
8 Mechanical Information	22
8.1 Board Dimensions	22
8.2 Board Connectors	23
9 Certifications	24
9.1 Certifications Summary	24
9.2 Declaration of Conformity CE DoC (EU)	24
9.3 Declaration of Conformity to EU RoHS & REACH 211 01/19/2021	24
9.4 Conflict Minerals Declaration	25
9.5 FCC Caution	25
10 Revision History	27

1 Application Examples

The Arduino Due combines the performance of the Atmel SAM3X8E microcontroller with the flexibility of the Arduino platform, offering a versatile solution for developers, hobbyists, and professionals alike. With its 32-bit architecture and clock speed of 84 MHz, the Due delivers robust performance for demanding applications.

- **Embedded Systems Development:** The Arduino Due can be utilized to create a real-time data acquisition system for monitoring and analyzing environmental parameters in industrial settings. By interfacing sensors such as temperature, humidity, and pressure sensors with the Due's abundant I/O pins, developers can capture real-time data and process it using the Due's powerful microcontroller. The system can then transmit this data wirelessly or via USB to a host computer for analysis, allowing for continuous monitoring and remote management of critical processes.
- **Robotics:** The Arduino Due can serve as the brain of an autonomous mobile robot capable of navigating and interacting with its environment. By integrating sensors such as ultrasonic range finders, gyroscopes, and encoders, developers can equip the robot with perception capabilities to sense its surroundings and detect obstacles. Using the Due's abundant I/O pins and powerful processing capabilities, algorithms for localization, mapping, and path planning can be implemented to enable autonomous navigation. Additionally, actuators such as motors or servos can be controlled by the Due to execute motion commands, allowing the robot to move and manipulate objects in its environment autonomously.
- **3D Printing & CNC Machines:** The Arduino Due can function as a versatile controller for DIY projects. By interfacing stepper motor drivers and end-stop switches with the Due's numerous I/O pins, enthusiasts can create their own 3D printers or CNC machines. The Due's high-speed processing capabilities enable precise control of stepper motors for accurate positioning and movement.
- **Prototyping:** The Arduino Due serves as an invaluable tool for quickly iterating and testing new ideas for IoT devices. By leveraging the Due's extensive I/O capabilities and compatibility with various sensors, communication modules, and actuators, developers can rapidly assemble and test prototypes of IoT devices. Whether it is a smart home sensor node, a weather station, or a remote monitoring system, the Arduino Due provides a flexible platform for integrating components, writing firmware, and validating functionality. With the Due's support for Arduino libraries and easy-to-use development environment, prototypers can focus on innovation and experimentation, accelerating the process of bringing ideas to fruition.

2 Features

2.1 General Specifications Overview

The Arduino Due is a versatile microcontroller board designed for a wide range of applications. Powered by the Atmel SAM3X8E ARM Cortex-M3 CPU, it offers high performance and a robust set of features, making it suitable for complex projects. The Due's 32-bit architecture provides enhanced processing capabilities compared to traditional Arduino boards. Designed with a similar form factor to the Arduino® Mega, it maintains compatibility with most Arduino shields through its extensive set of I/O pins and headers. The following table summarizes the board's main features.

Feature	Description
Microcontroller	Atmel SAM3X8E ARM Cortex-M3 32-bit ARM Cortex-M3 / 84 MHz Clock speed
Memory	SAM3X 512 KB Flash / 96 KB SRAM (divided into two banks: 64 KB and 32 KB)
USB-to-serial	ATmega16U2 connected to the SAM3X hardware UART
Digital Inputs	Digital Inputs not 5 V compatible (x54)
Analog Inputs	The Due's analog inputs pins measure from ground to a maximum value of 3.3 V (x12)
PWM Pins	PWM Pins with 8 bits resolution (x12)
Communication	UART (x4), I2C (x2), SPI (x1 SPI header), Native USB port (x1), Programming USB port (x1)
Power	Input voltage (VIN): 7-12 VDC / DC Current per I/O Pin: 8 mA
Dimensions	101.6 mm x 53.34 mm
Weight	36 g
Operating Temperature	-40 °C to +85 °C
Certifications	CE/RED, UKCA, FCC, IC, RCM, RoHS, REACH, WEEE

2.2 Microcontroller

Component	Details
Atmel SAM3X8E	32-bit ARM Cortex-M3 at 84 MHz
Flash Memory	512 KB
Programming Memory	96 KB SRAM (divided into two banks: 64 KB and 32 KB)

2.3 Inputs

Characteristics	Details
Number of inputs	54x digital inputs, 12x analog inputs
Inputs overvoltage protection	Yes
Antipolarity protection	Yes

2.4 Outputs

Characteristics	Details
DAC1 and DAC2	True analog output 12-bits resolution (4096 levels)
PWM outputs	12x PWM outputs

3 Accessories

- USB Cable Type-A Male to Micro Type-B Male (Not included)

4 Related Products

- Arduino Mega Proto Shield Rev3 (A000080)
- Arduino 4 Relays Shield (A000110)
- Arduino Motor Shield Rev3 (A000079)

5 Rating

5.1 Recommended Operating Conditions

Symbol	Description	Min	Typ	Max	Unit
V_{IN}	Input voltage from VIN pad	6.0	7.0	16	V
V_{USB}	Input voltage from USB connector	4.8	5.0	5.5	V
V_{DD}	Input high-level voltage	$0.7 \cdot V_{DD}$		V_{DD}	V
V_{IL}	Input low-level voltage	0		$0.3 \cdot V_{DD}$	V
T_{OP}	Operating Temperature	-40	25	85	°C

Note: V_{DD} controls the logic level and is connected to the 3.3 V power rail. V_{AREF} is for the analog logic.

5.2 Power Specification

Property	Min	Typ	Max	Unit
Supply voltage	7.0	-	12	V
Permissible range	6.0	-	16	V

Safety Note: Unlike most traditional Arduino boards, the Arduino Due board runs at 3.3 V. Keep in mind the maximum voltage that the I/O pins can tolerate is 3.3 V. Applying voltages higher than 3.3 V to any I/O pin could damage the board.

5.3 Current Consumption

Parameter	Symbol	Min	Typ	Max	Unit
Normal Mode Current Consumption	I_{NM}	130	---	800	mA

6 Functional Overview

6.1 Pinout

The Arduino Due pinout is shown in the following figure.

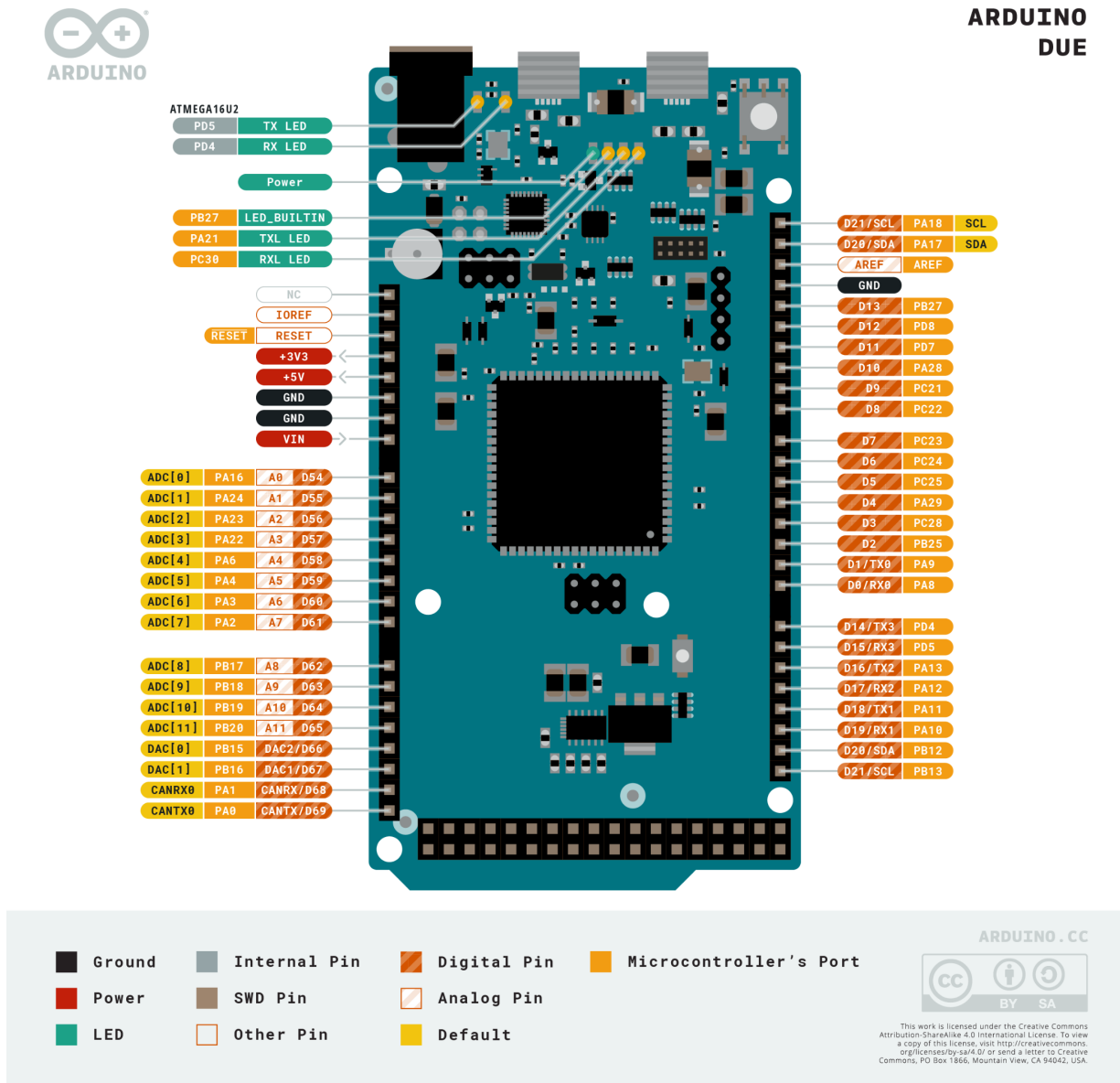

Arduino Due pinout

Safety Note: Disconnect power before board modifications to avoid short-circuiting.

6.2 Full Pinout Table

The full pinout of the Arduino Due is available in the following tables.

6.2.1 Board's 24-Pin Header

Pin	Function	Type	Description
1	NC	NC	Not Connected
2	IOREF	IOREF	Reference for digital logic voltage - connected to 3.3 V
3	Reset	Reset	Reset
4	+3V3	Power	+3V3 Power Rail
5	+5V	Power	+5V Power Rail
6	GND	Power	Ground
7	GND	Power	Ground
8	VIN	Power	Voltage Input
9	A0	Analog	Analog input 0 / GPIO
10	A1	Analog	Analog input 1 / GPIO
11	A2	Analog	Analog input 2 / GPIO
12	A3	Analog	Analog input 3 / GPIO
13	A4	Analog	Analog input 4 / GPIO
14	A5	Analog	Analog input 5 / GPIO
15	A6	Analog	Analog input 6 / GPIO
16	A7	Analog	Analog input 7 / GPIO
17	A8	Analog	Analog input 8 / GPIO
18	A9	Analog	Analog input 9 / GPIO
19	A10	Analog	Analog input 10 / GPIO
20	A11	Analog	Analog input 11 / GPIO
21	DAC0	Analog	Digital to Analog Converter 0
22	DAC1	Analog	Digital to Analog Converter 1
23	CANRX	Digital	CAN Bus Receiver
24	CANTX	Digital	CAN Bus Transmitter

Board's 24-Pin Header pinout

6.2.2 Board's 26-Pin Header

Pin	Function	Type	Description
1	D21/SCL1	Digital	GPIO 21 / I2C 1 Clock
2	D20/SDA1	Digital	GPIO 20 / I2C 1 Dataline
3	AREF	Digital	Analog Reference Voltage
4	GND	Power	Ground
5	D13/SCK	Digital	GPIO 13 / SPI Clock (PWM~)
6	D12/CIPO	Digital	GPIO 12 / SPI Controller In Peripheral Out (PWM~)
7	D11/COPI	Digital	GPIO 11 / SPI Controller Out Peripheral In (PWM~)
8	D10/CS	Digital	GPIO 10 / SPI Chip Select (PWM~)
9	D9/SDA2	Digital	GPIO 9 / I2C 2 Dataline (PWM~)
10	D8/SCL2	Digital	GPIO 8 / I2C 2 Clockline (PWM~)
11	D7	Digital	GPIO 7 (PWM~)
12	D6	Digital	GPIO 6 (PWM~)
13	D5	Digital	GPIO 5 (PWM~)
14	D4	Digital	GPIO 4 (PWM~)
15	D3	Digital	GPIO 3 (PWM~)
16	D2	Digital	GPIO 2 (PWM~)
17	D1/TX0	Digital	GPIO 1 / Serial 0 Transmitter
18	D0/TX0	Digital	GPIO 0 / Serial 0 Receiver
19	D14/TX3	Digital	GPIO 14 / Serial 3 Transmitter
20	D15/RX3	Digital	GPIO 15 / Serial 3 Receiver
21	D16/TX2	Digital	GPIO 16 / Serial 2 Transmitter
22	D17/RX2	Digital	GPIO 17 / Serial 2 Receiver
23	D18/TX1	Digital	GPIO 18 / Serial 1 Transmitter
24	D19/RX1	Digital	GPIO 19 / Serial 1 Receiver
25	D20/SDA	Digital	GPIO 20 / I2C 0 Dataline
26	D21/SCL	Digital	GPIO 21 / I2C 0 Clock

Board's 26-Pin Header pinout

6.2.3 SPI

The board provides an SPI interface and full access to its pinout as it can be seen in the following table.

Pin	Function	Type	Description
1	CIPO	Internal	Controller In Peripheral Out
2	+5V	Internal	Power Supply of 5V
3	SCK	Internal	Serial Clock
4	COPI	Internal	Controller Out Peripheral In
5	RESET	Internal	Reset
6	GND	Internal	Ground

SPI pinout

6.2.4 Digital Pins D22 - D53 LHS

Pin	Function	Type	Description
1	+5V	Power	+5V Power Rail
2	D22	Digital	GPIO 22
3	D24	Digital	GPIO 24
4	D26	Digital	GPIO 26
5	D28	Digital	GPIO 28
6	D30	Digital	GPIO 30
7	D32	Digital	GPIO 32
8	D34	Digital	GPIO 34
9	D36	Digital	GPIO 36
10	D38	Digital	GPIO 38
11	D40	Digital	GPIO 40
12	D42	Digital	GPIO 42
13	D44	Digital	GPIO 44
14	D46	Digital	GPIO 46
15	D48	Digital	GPIO 48
16	D50	Digital	GPIO 50
17	D52	Digital	GPIO 52
18	GND	Power	Ground

D22 - D53 LHS pinout

6.2.5 Digital Pins D22 - D53 RHS

Pin	Function	Type	Description
1	+5V	Power	+5V Power Rail
2	D23	Digital	GPIO 23
3	D25	Digital	GPIO 25
4	D27	Digital	GPIO 27
5	D29	Digital	GPIO 29
6	D31	Digital	GPIO 31
7	D33	Digital	GPIO 33
8	D35	Digital	GPIO 35
9	D37	Digital	GPIO 37
10	D39	Digital	GPIO 39
11	D41	Digital	GPIO 41
12	D43	Digital	GPIO 43
13	D45	Digital	GPIO 45
14	D47	Digital	GPIO 47
15	D49	Digital	GPIO 49
16	D51	Digital	GPIO 51
17	D53	Digital	GPIO 53
18	GND	Power	Ground

D22 - D53 RHS pinout

6.2.6 JTAG Pins

The board provides access to the debugging interface using the JTAG pins as it can be seen in the following table.

Pin	Function	Type	Description
1	Reset	Reset	Reset
2	GND	Power	GROUND
3	TDI	Digital	Test Data In
4	N/C	-	Not Connected
5	TDO	Digital	Test Data Out
6	GND	Power	GROUND
7	TCK	Digital	Test Clock
8	GND	Power	GROUND
9	TMS	Digital	Test Mode Select
10	+3V3	Power	+3V3 Power Rail

Debugging's JTAG pinout

6.3 Block Diagram

The block diagram with the main parts of the product can be checked in the following image:

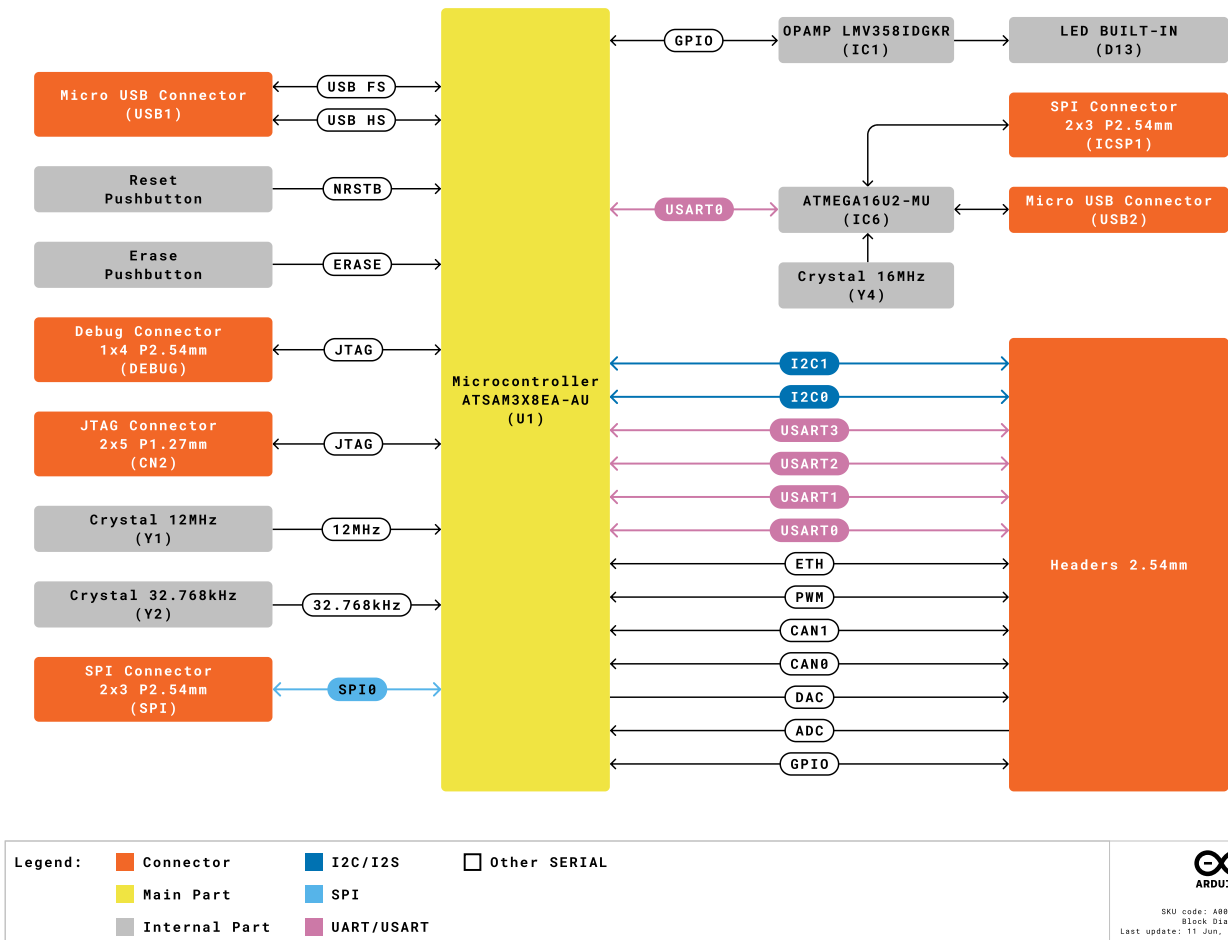

Arduino Due Block Diagram

6.5 Product Topology

In the following drawing you can see the main integrated circuits and passive components of the Arduino Due board.

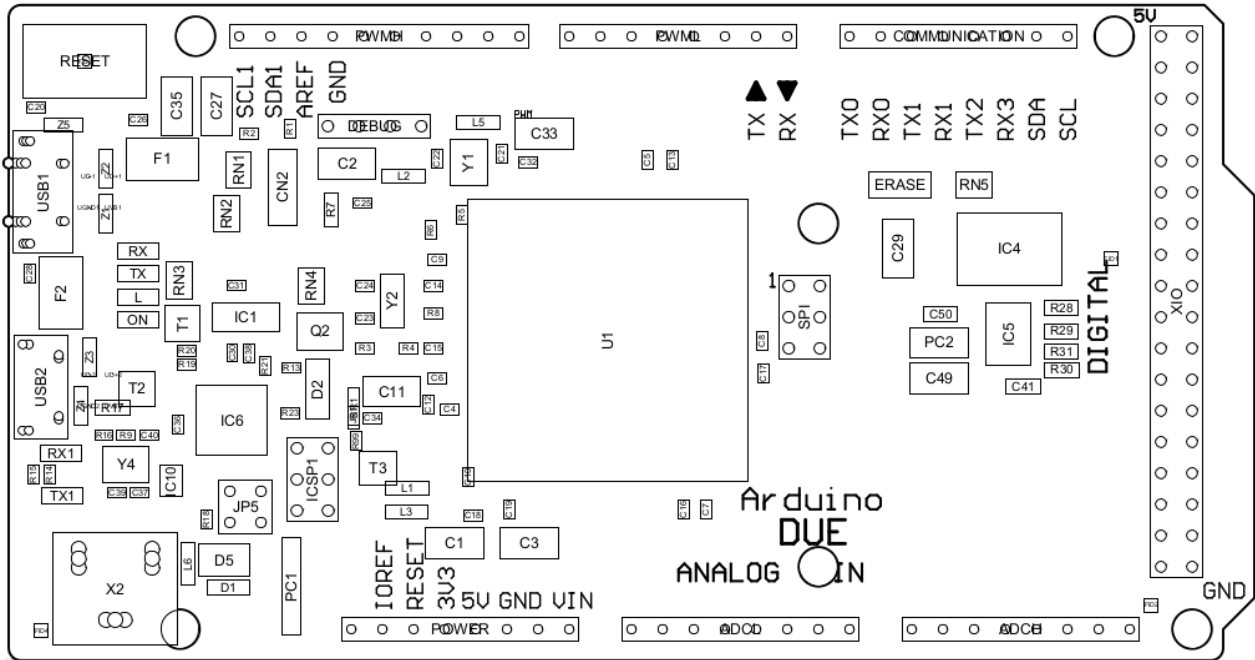

Arduino Due Topology

Ref.	Description
U1	Atmel SAM3X8E ARM Cortex-M3
USB1	Native USB port
USB2	Programming USB port
X2	Power Jack VIN 7-12 VCC
ERASE	ERASE Button
RESET	Reset Button
DEBUG	Debug JTAG pinnout
SPI	SPI pinout
ICSP1	ICSP1 Pinout

6.5.1 JTAG Connector

Debugging capabilities are integrated directly into the Arduino Due and are accessible via the 6-pin JTAG connector.

Pin	Function	Type	Description
1	Reset	Reset	Reset
2	GND	Power	GROUND
3	TDI	Digital	Test Data In
4	N/C	-	Not Connected
5	TDO	Digital	Test Data Out
6	GND	Power	GROUND
7	TCK	Digital	Test Clock
8	GND	Power	GROUND
9	TMS	Digital	Test Mode Select
10	+3V3	Power	+3V3 Power Rail

JTAG pinout

6.5.2 Native USB Port

The Arduino Due's Native USB port features a USB Type-B connector. This port allows the board to communicate directly with a computer as a USB device, enabling functionalities such as USB host/device capabilities and USB OTG (On-The-Go) functionality.

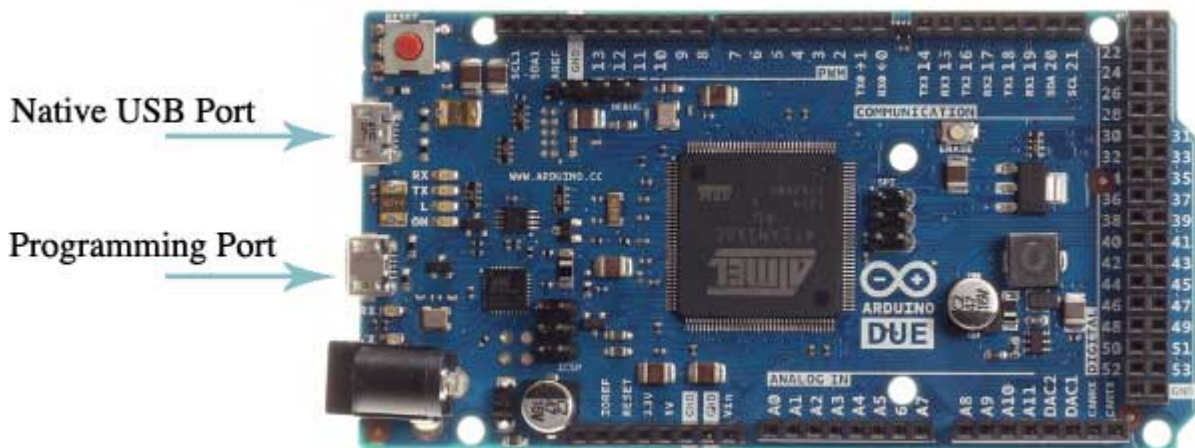

Arduino Due USB port

6.5.3 Programming USB Port

This port allows the board to be programmed and powered via a USB connection to a computer. It facilitates serial communication between the Arduino Due and the computer, enabling the uploading of sketches and interaction with the Arduino IDE. The port is connected to the ATmega16U2 microcontroller, which acts as a USB-to-serial converter, simplifying the programming process. When connected to a computer, the Arduino IDE recognizes the board as a COM port, enabling seamless communication for programming and debugging purposes.

6.5.4 Board's 24-Pin Header Connector

The 24-pin header connector provides a range of interfaces and general-purpose pins essential for various applications

These pins offer a range of functionalities, including analog and digital input/output, power supply connections, analog-to-digital, digital-to-analog conversion and CAN bus communication.

Pin	Function	Type	Description
1	NC	NC	Not Connected
2	IOREF	IOREF	Reference for digital logic voltage - connected to 3.3V
3	Reset	Reset	Reset
4	+3V3	Power	+3V3 Power Rail
5	+5V	Power	+5V Power Rail
6	GND	Power	Ground
7	GND	Power	Ground
8	VIN	Power	Voltage Input
9	A0	Analog	Analog input 0 / GPIO
10	A1	Analog	Analog input 1 / GPIO
11	A2	Analog	Analog input 2 / GPIO
12	A3	Analog	Analog input 3 / GPIO
13	A4	Analog	Analog input 4 / GPIO
14	A5	Analog	Analog input 5 / GPIO
15	A6	Analog	Analog input 6 / GPIO
16	A7	Analog	Analog input 7 / GPIO
17	A8	Analog	Analog input 8 / GPIO
18	A9	Analog	Analog input 9 / GPIO
19	A10	Analog	Analog input 10 / GPIO
20	A11	Analog	Analog input 11 / GPIO
21	DAC0	Analog	Digital to Analog Converter 0
22	DAC1	Analog	Digital to Analog Converter 1
23	CANRX	Digital	CAN Bus Receiver
24	CANTX	Digital	CAN Bus Transmitter

Board's 24-Pin Header pinout

6.5.5 Board's 26-Pin Header Connector

The 26-pin header connector on the Arduino Due offers a comprehensive set of interfaces and versatile pins crucial for diverse applications

These pins offer a range of functionalities, including digital input/output, serial communication, PWM (Pulse Width Modulation) outputs, and I2C (Inter-Integrated Circuit) communication.

Pin	Function	Type	Description
1	D21/SCL1	Digital	GPIO 21 / I2C 1 Clock
2	D20/SDA1	Digital	GPIO 20 / I2C 1 Dataline
3	AREF	Digital	Analog Reference Voltage
4	GND	Power	Ground
5	D13/SCK	Digital	GPIO 13 / SPI Clock (PWM~)
6	D12/CIPO	Digital	GPIO 12 / SPI Controller In Peripheral Out (PWM~)
7	D11/COPI	Digital	GPIO 11 / SPI Controller Out Peripheral In (PWM~)
8	D10/CS	Digital	GPIO 10 / SPI Chip Select (PWM~)
9	D9/SDA2	Digital	GPIO 9 / I2C 2 Dataline (PWM~)
10	D8/SCL2	Digital	GPIO 8 / I2C 2 Clockline (PWM~)
11	D7	Digital	GPIO 7 (PWM~)
12	D6	Digital	GPIO 6 (PWM~)
13	D5	Digital	GPIO 5 (PWM~)
14	D4	Digital	GPIO 4 (PWM~)
15	D3	Digital	GPIO 3 (PWM~)
16	D2	Digital	GPIO 2 (PWM~)
17	D1/TX0	Digital	GPIO 1 / Serial 0 Transmitter
18	D0/TX0	Digital	GPIO 0 / Serial 0 Receiver
19	D14/TX3	Digital	GPIO 14 / Serial 3 Transmitter
20	D15/RX3	Digital	GPIO 15 / Serial 3 Receiver
21	D16/TX2	Digital	GPIO 16 / Serial 2 Transmitter
22	D17/RX2	Digital	GPIO 17 / Serial 2 Receiver
23	D18/TX1	Digital	GPIO 18 / Serial 1 Transmitter
24	D19/RX1	Digital	GPIO 19 / Serial 1 Receiver
25	D20/SDA	Digital	GPIO 20 / I2C 0 Dataline
26	D21/SCL	Digital	GPIO 21 / I2C 0 Clock

Board's 26-Pin Header pinout

6.5.6 SPI

These pins facilitate communication between the Arduino Due and external SPI devices

Pin	Function	Type	Description
1	CIPO	Internal	Controller In Peripheral Out
2	+5V	Internal	Power Supply of 5 V
3	SCK	Internal	Serial Clock
4	COPI	Internal	Controller Out Peripheral In
5	RESET	Internal	Reset
6	GND	Internal	Ground

SPI pinout

6.5.7 D22 to D53 on Left and Right Side

These digital pins provide a wide range of GPIO (General Purpose Input/Output) capabilities for interfacing with external sensors, actuators, and other digital devices in Arduino Due projects.

Pin	Function	Type	Description
1	+5V	Power	+5V Power Rail
2	D22	Digital	GPIO 22
3	D24	Digital	GPIO 24
4	D26	Digital	GPIO 26
5	D28	Digital	GPIO 28
6	D30	Digital	GPIO 30
7	D32	Digital	GPIO 32
8	D34	Digital	GPIO 34
9	D36	Digital	GPIO 36
10	D38	Digital	GPIO 38
11	D40	Digital	GPIO 40
12	D42	Digital	GPIO 42
13	D44	Digital	GPIO 44
14	D46	Digital	GPIO 46
15	D48	Digital	GPIO 48
16	D50	Digital	GPIO 50
17	D52	Digital	GPIO 52
18	GND	Power	Ground

D22 - D53 LHS pinout



Pin	Function	Type	Description
1	+5V	Power	+5V Power Rail
2	D23	Digital	GPIO 23
3	D25	Digital	GPIO 25
4	D27	Digital	GPIO 27
5	D29	Digital	GPIO 29
6	D31	Digital	GPIO 31
7	D33	Digital	GPIO 33
8	D35	Digital	GPIO 35
9	D37	Digital	GPIO 37
10	D39	Digital	GPIO 39
11	D41	Digital	GPIO 41
12	D43	Digital	GPIO 43
13	D45	Digital	GPIO 45
14	D47	Digital	GPIO 47
15	D49	Digital	GPIO 49
16	D51	Digital	GPIO 51
17	D53	Digital	GPIO 53
18	GND	Power	Ground

D22 - D53 RHS pinout

7 Device Operation

7.1 Getting Started - IDE

If you want to program your Arduino Due while offline you need to install the Arduino® Desktop IDE **[1]**. To connect the Arduino Due to your computer, you will need a USB Type-B cable, which can also provide power to the board, as indicated by the LED (DL1).

7.2 Getting Started - Arduino Web Editor

All Arduino boards, including this one, work out-of-the-box on the Arduino® Web Editor **[2]**, by just installing a simple plugin.

The Arduino Web Editor is hosted online, therefore it will always be up-to-date with the latest features and support for all boards. Follow **[3]** to start coding on the browser and upload your sketches onto your board.

7.3 Getting Started - Arduino Cloud

All Arduino IoT enabled products are supported on Arduino Cloud which allows you to log, graph and analyze sensor data, trigger events, and automate your home or business.

7.4 Online Resources

Now that you have gone through the basics of what you can do with the board you can explore the endless possibilities it provides by checking exciting projects on ProjectHub **[4]**, the Arduino Library Reference **[5]**, and the online store **[6]**; where you will be able to complement your board with sensors, actuators and more.

7.5 Board Recovery

All Arduino boards have a built-in bootloader which allows flashing the board via USB. In case a sketch locks up the processor and the board is not reachable anymore via USB, it is possible to enter bootloader mode by double-tapping the reset button right after the power-up.

8 Mechanical Information

The Arduino Due is a microcontroller board measuring 101.52 mm x 53.3 mm, featuring two USB-B connectors and a big quantity of GPIO pins headers.

8.1 Board Dimensions

The Arduino Due board outline and mounting holes dimensions are shown in the figure below; all the dimensions are in mm.

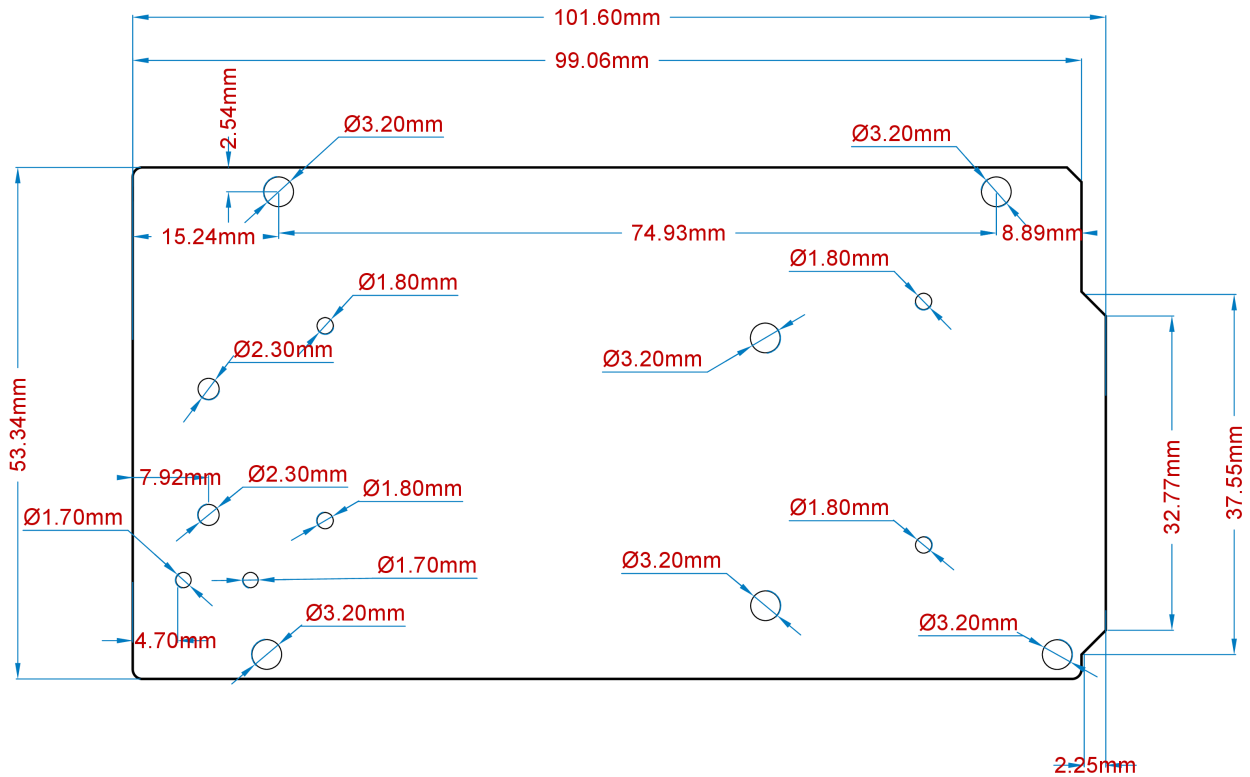

Arduino Due Mounting Holes And Board Outline

8.2 Board Connectors

Connectors of the Arduino Due are placed on the left side of the board; their placement is shown in the figure below. All the dimensions are in mm.

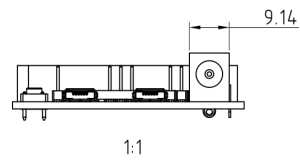
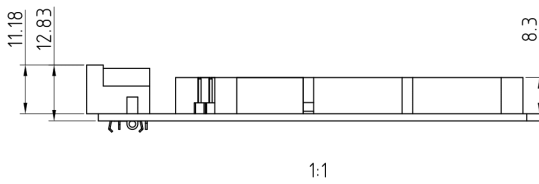
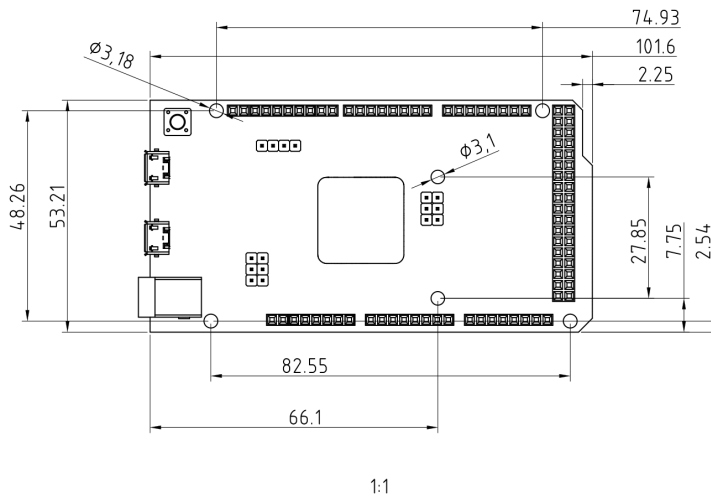

Arduino
Due
Technical
drawing

Arduino Due Technical drawing

9 Certifications

9.1 Certifications Summary

Certification	Status
CE/RED (Europe)	Yes
UKCA (UK)	Yes
FCC (USA)	Yes
IC (Canada)	Yes
RCM (Australia)	Yes
RoHS	Yes
REACH	Yes
WEEE	Yes

9.2 Declaration of Conformity CE DoC (EU)

We declare under our sole responsibility that the products above are in conformity with the essential requirements of the following EU Directives and therefore qualify for free movement within markets comprising the European Union (EU) and European Economic Area (EEA).

9.3 Declaration of Conformity to EU RoHS & REACH 211 01/19/2021

Arduino boards are in compliance with RoHS 2 Directive 2011/65/EU of the European Parliament and RoHS 3 Directive 2015/863/EU of the Council of 4 June 2015 on the restriction of the use of certain hazardous substances in electrical and electronic equipment.

Substance	Maximum limit (ppm)
Lead (Pb)	1000
Cadmium (Cd)	100
Mercury (Hg)	1000
Hexavalent Chromium (Cr6+)	1000
Poly Brominated Biphenyls (PBB)	1000
Poly Brominated Diphenyl ethers (PBDE)	1000
Bis(2-Ethylhexyl) phthalate (DEHP)	1000
Benzyl butyl phthalate (BBP)	1000
Dibutyl phthalate (DBP)	1000
Diisobutyl phthalate (DIBP)	1000

Exemptions: No exemptions are claimed.

Arduino Boards are fully compliant with the related requirements of European Union Regulation (EC) 1907 /2006 concerning the Registration, Evaluation, Authorization and Restriction of Chemicals (REACH). We declare none of the SVHCs (<https://echa.europa.eu/web/guest/candidate-list-table>), the Candidate List of Substances of Very High Concern for authorization currently released by ECHA, is present in all products (and also package) in quantities totaling in a concentration equal or above 0.1%. To the best of our knowledge, we also declare that our products do not contain any of the substances listed on the "Authorization List" (Annex XIV of the REACH regulations) and

Substances of Very High Concern (SVHC) in any significant amounts as specified by the Annex XVII of Candidate list published by ECHA (European Chemical Agency) 1907 /2006/EC.

9.4 Conflict Minerals Declaration

As a global supplier of electronic and electrical components, Arduino is aware of our obligations with regard to laws and regulations regarding Conflict Minerals, specifically the Dodd-Frank Wall Street Reform and Consumer Protection Act, Section 1502. Arduino does not directly source or process conflict minerals such as Tin, Tantalum, Tungsten, or Gold. Conflict minerals are contained in our products in the form of solder or as a component in metal alloys. As part of our reasonable due diligence, Arduino has contacted component suppliers within our supply chain to verify their continued compliance with the regulations. Based on the information received thus far we declare that our products contain Conflict Minerals sourced from conflict-free areas.

9.5 FCC Caution

Any Changes or modifications not expressly approved by the party responsible for compliance could void the user's authority to operate the equipment.

This device complies with part 15 of the FCC Rules. Operation is subject to the following two conditions:

- (1) This device may not cause harmful interference
- (2) this device must accept any interference received, including interference that may cause undesired operation.

FCC RF Radiation Exposure Statement:

1. This Transmitter must not be co-located or operating in conjunction with any other antenna or transmitter.
2. This equipment complies with RF radiation exposure limits set forth for an uncontrolled environment.
3. This equipment should be installed and operated with a minimum distance of 20 cm between the radiator & your body.

Note: This equipment has been tested and found to comply with the limits for a Class B digital device, pursuant to part 15 of the FCC Rules. These limits are designed to provide reasonable protection against harmful interference in a residential installation. This equipment generates, uses and can radiate radio frequency energy and, if not installed and used in accordance with the instructions, may cause harmful interference to radio communications. However, there is no guarantee that interference will not occur in a particular installation. If this equipment does cause harmful interference to radio or television reception, which can be determined by turning the equipment off and on, the user is encouraged to try to correct the interference by one or more of the following measures:

- Reorient or relocate the receiving antenna.
- Increase the separation between the equipment and receiver.
- Connect the equipment into an outlet on a circuit different from that to which the receiver is connected.
- Consult the dealer or an experienced radio/TV technician for help.

English: User manuals for license-exempt radio apparatus shall contain the following or equivalent notice in a conspicuous location in the user manual or alternatively on the device or both. This device complies with Industry Canada license-exempt RSS standard(s). Operation is subject to the following two conditions:

- (1) this device may not cause interference

(2) this device must accept any interference, including interference that may cause undesired operation of the device.

French: Le présent appareil est conforme aux CNR d'Industrie Canada applicables aux appareils radio exempts de licence. L'exploitation est autorisée aux deux conditions suivantes:

(1) l'appareil n' doit pas produire de brouillage

(2) l'utilisateur de l'appareil doit accepter tout brouillage radioélectrique subi, même si le brouillage est susceptible d'en compromettre le fonctionnement.

IC SAR Warning:

English: This equipment should be installed and operated with a minimum distance of 20 cm between the radiator and your body.

French: Lors de l' installation et de l' exploitation de ce dispositif, la distance entre le radiateur et le corps est d' au moins 20 cm.

Important: The operating temperature of the EUT can't exceed 85°C and shouldn't be lower than -40°C.

Hereby, Arduino S.r.l. declares that this product is in compliance with essential requirements and other relevant provisions of Directive 2014/53/EU. This product is allowed to be used in all EU member states.

Company Information

Company name	Arduino SRL
Company Address	Via Andrea Appiani, 25 - 20900 MONZA (Italy)

Reference Documentation

Ref	Link
Arduino IDE (Desktop)	https://www.arduino.cc/en/Main/Software
Arduino IDE (Cloud)	https://create.arduino.cc/editor
Cloud IDE Getting Started	https://docs.arduino.cc/cloud/web-editor/tutorials/getting-started/getting-started-web-editor
Project Hub	https://create.arduino.cc/projecthub?by=part&part_id=11332&sort=trending
Library Reference	https://github.com/arduino-libraries/
Online Store	https://store.arduino.cc/



10 Revision History

Date	Revision	Changes
12/06/2024	1	First release